

User manual
Spectar Foam – Cervical Collar

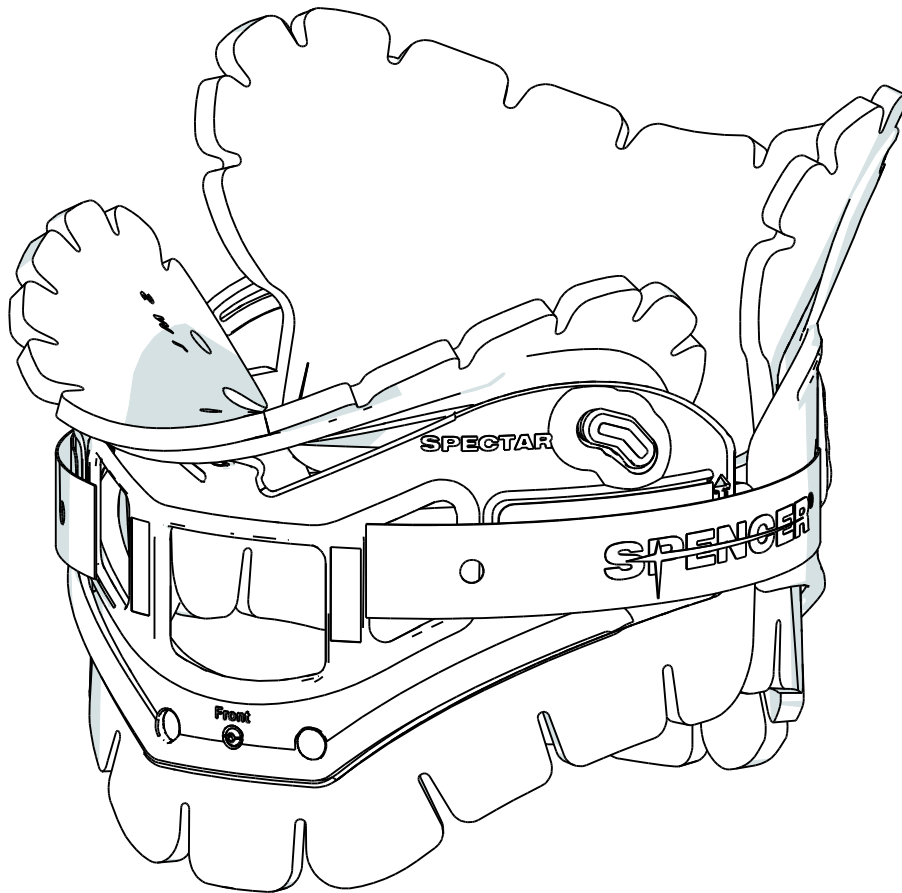

CE Class I Medical Device, compliant with the Medical device directive 93/42/EEC

Warning

The information contained in this manual is subject to change without notice.

The Diagrams are inserted only for reference and may vary slightly from the actual device.

Spencer Italia S.r.l. assumes no responsibility for any errors contained herein or for damage, accidents or consequences connected with the supply, performance or use of this manual.

First edition: 15/09/2014
Rev. 2: 04/06/2015



INDEX

1. MODELS	3
2. INTENDED USE	3
3. REFERENCE STANDARDS	3
4. INTRODUCTION	3
4.1 Use of the manual	3
4.2 Labelling and tracking control of the device	3
4.3 Symbols	3
4.4 Warranty and support	4
5. WARNINGS	4
6. SPECIFIC WARNINGS	6
6.1 Physical requirements of operators	6
7. RESIDUAL RISK	6
8. TECHNICAL DATA AND COMPONENTS	7
9. START-UP	7
10. FUNCTIONAL CHARACTERISTICS	8
11. INSTRUCTIONS FOR USE	9
12. CLEANING AND MAINTENANCE	10
12.1 Cleaning	10
12.2 Precautionary maintenance	10
12.3 Periodic maintenance	10
12.4 Special servicing	10
12.5 Life span	10
13. TROUBLESHOOTING	11
14. ACCESSORIES	11
15. SPARE PARTS	11
16. DEMOLITION	11

Warning

The information contained in this document could be modified without any warning and is not to be intended as a commitment on behalf of Spencer Italia S.r.l. Spencer products are exported to many countries and the same identical regulations are not always valid. For this reason there could be differences between the description here described and the product actually delivered. Spencer continually strives to reach the perfection of all items sold. We therefore hope you will understand if we reserve the right, at any time, to modify the shape, equipment, lay-out or technical aspects that are herein described.

© Copyright Spencer Italia S.r.l.

All rights reserved. No part of this document can be photocopied, reproduced or translated into another language without the written approval of Spencer Italia S.r.l.

1. MODELS

The standard following models can undergo change, revision and implementation without any notice.

SPECTAR FOAM – CERVICAL COLLAR BICOMPONENT SIZE XXS
SPECTAR FOAM – CERVICAL COLLAR BICOMPONENT SIZE XS
SPECTAR FOAM – CERVICAL COLLAR BICOMPONENT SIZE S
SPECTAR FOAM – CERVICAL COLLAR BICOMPONENT SIZE M
SPECTAR FOAM – CERVICAL COLLAR BICOMPONENT SIZE L
SPECTAR FOAM – CERVICAL COLLAR BICOMPONENT SIZE STOUT

2. INTENDED USE

The two piece cervical collar Spectar Foam is designed for use in first aid and emergency situations. It's identified as a solution for the immobilization of the cervical spine in trauma patients.

The device contains latex and may cause anaphylactic shock in subjects allergic to that substance

3. REFERENCE STANDARDS

As a distributor or end user of products manufactured and/or marketed by Spencer Italia S.r.l. you are strictly required to have basic knowledge of any legal requirements applying to the devices contained in this supply that are in power in the goods final destination Country (including laws and norms regarding technical specifications and/or safety requirements) and therefore you are strictly required to have the necessary knowledge to guarantee all aspects regarding the total conformity of the products to the regulations in the relevant territory.

4. INTRODUCTION

4.1 Use of the manual

This manual is intended to provide the health care operator with the all the necessary information for its safe and appropriate use as well as adequate maintenance of the device

Note: The manual is an integral part of the device. It must be kept for the duration of the device and must accompany the device in case of change of ownership or destination. If the operating instructions received relate to products not received, you must immediately contact the manufacturer before use.

The Spencer product manuals can be downloaded from the website or can be requested by <http://support.spencer.it> or by contacting the manufacturer. Exceptions are items whose essentiality for reasonable and predictable use is such as to make it unnecessary to prepare instructions in addition to the following warnings and directions on the label.

Regardless of the level of experience gained in the past with similar devices, it is recommended that you carefully read this manual before installing, operating or using the product or any maintenance

4.2 Labelling and tracking control of the device







Each device has got an identification label positioned on the device itself and/or on its box, which includes identification data about the manufacturer, the product, the CE mark, the serial number (SN) or lot number (LOT).

It must never be removed or covered.

In case of damage or loss, request a duplicate from the manufacturer. Failure to do so will interrupt the validity of the guarantee as the device can no longer be traced.

The Directive 93/42/EEC requires manufacturers and distributors of medical devices to keep track of the device location. If the device was in a different location to the address where it was sent or to where it had been sold, donated, lost, stolen, exported, or destroyed, permanently removed from use, or if the device had not been delivered directly from Spencer Italia S.r.l., register your device at <http://service.spencer.it> or inform the customer (see § 4.4).

4.3 Symbols

Symbol	Meaning
	General or specific warnings
	Single patient use
	See instructions for use
	Lot number
	Product code
	The product is compliant with the requirements of Directive 93/42/EEC

4.4 Warranty and support

Spencer Italia S.r.l. guarantees that products are without defects for a period of one year from the date of purchase.

For any information regarding the correct interpretation of the instruction manual, the use, maintenance, installation and restore of the product, contact the Spencer customer care service ph. +39.0521.541111, fax +39.0521.541222 or e-mail service@spencer.it.

In order to facilitate the assistance service, please always indicate the lot number (LOT) or serial number (SN) shown on the label applied on the box or on the device.

Conditions for warranty and assistance can be viewed on <http://support.spencer.it>.

Note: Record and store; these instructions, lot (LOT) or serial number (SN) if any, date and place of purchase, date of first use, date servicing, user names and comments.

5. WARNINGS

The warnings, notes and other important safety information are indicated in this section and are clearly visible throughout the entire manual.

User training

Note: Laboratory testing, post production tests, instruction manuals cannot always consider every possible scenario for use. This means that in some cases the performance of the product could be notable different from results to date obtained. Instructions are continually being updated and are under tight surveillance of fully qualified staff with adequate technical formation.

- Regardless of the level of experience gained previously with similar devices, it is recommended that you carefully read this manual before installing, operating or using the product or carrying out any maintenance. If in doubt, contact Spencer Italia S.r.l. to obtain the necessary clarifications.
- The product must be used by trained personnel only, having attended specific training for this device and not for similar products.
- The suitability of the user to use the product may be attested by the records of training, where the names of those trained, of the trainers, dates and place are indicated. **This register which certifies the eligibility of the operators to use the Spencer device must be kept for a period of 10 years after the disposal of the device itself. This register will be made available to the competent Authorities and/or manufacturer if requested. In the absence of such documentation, sanctions will be applied.**
- Do not allow any untrained person to help during the use of the device, because they could cause damage to the patient or to themselves.

Note: Spencer Italia S.r.l. is always at your disposal to organise product training.

Product functionality

Use of the device in anyway other than described in this manual is forbidden.

- Before any use of device, the perfect operating state of the device must be checked as specified in the instruction manual. If any damage or abnormalities which could in any way influence the correct functioning and the safety of the device are detected, the device must be immediately removed from service and the manufacturer must be contacted.
- If any failure or incorrect functioning of the device is detected, it must be immediately substituted with a similar item so that the rescue procedures are guaranteed without any interruption.
- The appliance must not in any way be tampered with (modification, adjustment, addition, replacement). In such cases all responsibility will be denied for any malfunctions or injuries caused by the appliance itself; moreover CE certification and product warranty will be considered void.
- Those who modify or have modified, prepare or have prepared medical appliances in such a way that they no longer serve the purpose for which they were intended, or no longer supply the intended service, must satisfy the valid conditions for the introduction onto the market.
- During use, position and adjust the device taking care not to cause any obstruction to rescuers and or any other rescue equipment
- Ensure that all the necessary precautions are taken in order to avoid the hazards that can arise as the result of contact with blood or body fluids, when applicable.
- Avoid contact with sharp objects.
- Operating temperature: from -5°C to +40°C

Storage

- The device should not be exposed to or come into contact with any source of combustion or inflammable agents. Store in a cool, dry, dark place and do not expose to direct sun
- Do not store the device underneath any heavy objects which could cause structural damage.
- Store and transport the device in its original packaging. Failure to do so makes the warranty void.
- Storage temperature: from -10°C to +50°C

Maintenance/cleaning

Spencer Italia S.r.l. disclaims any liability for any damage, direct or indirect, which is a result of improper use of the product and replacement parts and / or otherwise of any repairs made by an entity other than the authorized Spencer service centres; this will also invalidate the warranty.

- The operator must always wear adequate personal protection such as gloves and mask etc. during all checking, maintenance and cleaning procedures.
- Establish a maintenance program and periodic testing, identifying an employee responsible for overseeing. The person to whom the ordinary maintenance of the device is entrusted must ensure the basic requirements foreseen by the manufacturer in the user's manual.
- **The frequency of inspection is determined by factors such as legal requirements, the type of use, frequency of use, environmental conditions during use and storage.**
- Spencer Italia S.r.l. disclaims any liability for any damage, direct or indirect, that is the result of incorrect repairs or use of products made by Spencer Italia S.r.l. Repairs must necessarily be carried out by an authorized Spencer Italia service centre, which in using original spare parts will provide a quality repair service in strict accordance with the technical specifications given by the manufacturer. Spencer Italia S.r.l. disclaims any liability for any damage, direct or indirect, which is a result of improper use of spare parts and/or otherwise of any repairs made by an entity other than the Spencer service centres authorized to repair or make substitutions on this product and parts and/or otherwise of any repairs made by an entity other than the Spencer service centres authorized to do so; the warranty will also be invalidated.
- Use only original components, spare parts and or accessories, approved by Spencer Italia S.r.l., in order to carry out any operation without causing any alteration or modification to the device.
- For any operations that are not carried out directly by the manufacturer but by an authorised centre, we have to underline that a report regarding all operations carried out must be requested. This will permit both Spencer Italia S.r.l. and the end user to keep a log book regarding the operations carried out on the device.
- The cleaning schedule for reusable products must be performed in accordance with the directions provided by the manufacturer in the user manual, in order to avoid the risk of cross-infection due to the presence of secretions and/or residuals.
- The device and all its components, after washing, should be allowed to dry completely before storing.

Regulatory requirements

As a distributor or end user of products manufactured and/or marketed by Spencer Italia S.r.l., you are strictly required to have a basic knowledge of any legal requirements applying to the devices contained in this supply that are in power in the final destination Country (including laws and norms regarding technical specifications and/or safety requirements) of the goods and therefore you are also strictly required to have the necessary knowledge to guarantee all aspects regarding the total conformity of the products to the regulations in the relevant territory.

- Promptly notify Spencer Italia S.r.l. (already during the first product enquiry) when requesting in details regarding any revisions to be made by manufacturer in order to guarantee the conformity of the products to the territory's legal specifications (including those resulting from rules and/or norms of other kind).
- Act, with all due care and diligence, and contribute to ensure conformity to general safety requirements of all devices marketed in the territory, by providing final users with all necessary information for carrying out periodical checks on their devices, exactly as specified in the relevant user's manual.
- **Actively contribute to safety checks on product sold**, by communicating any relevant risk analysis information both to the manufacturer and to any competent authorities so that the necessary action can be promptly taken.
- The distributor or final user is aware that in the event of any failure to conform to the above mentioned requirements you will be deemed fully responsible for all damages that might occur. Therefore Spencer Italia S.r.l. expressly disclaims any responsibility and/or liability for your non-compliance with the present regulatory provisions.

General warnings for medical devices

When in possession of a medical device, the user must carefully read not only these general warnings, but also those listed below.

- It is not foreseen that the use of the device is prolonged beyond the time necessary for the first responders to the complete their operation and the subsequent stages of transport to the nearest rescue point.
- When the device is being used, the assistance of qualified staff must be guaranteed and at least one operator must be present.
- Follow the procedures and protocols approved by the internal organization.
- The activities of disinfection and sterilization should be carried out in accordance with the parameters given in the validated cycle as specified in the technical standards.
- With reference to the D. Lgs. 24th February 1997, n. 46 emended by D. Lgs. 25/01/2010, n. 37 – Acknowledgement of Directive 93/42/CEE and 2007/47/CE concerning Medical Devices, we remind both public and private operators, , That in the exercise of their activity detect an accident involving a medical product are required to notify the Ministry of Health, under the terms and in the manner established by the relative ministerial decrees and also to the manufacturer. Health care providers whether public or private are required to communicate to the manufacturer, any other inconvenience that may allow for the adoption of measures to ensure the protection and health of patients and users

6. SPECIFIC WARNINGS

- Follow the procedures approved by the Emergency Medical Service for the immobilization and transport of patients.
- This product is designed and tested to be used for a single patient and cannot be used for more than one patient.
- Do not use if the device or its parts are pierced, torn, frayed or excessively worn out.
- Do not wash in a washing machine device.
- Do not use drying machines.
- Do not use the device after the life span stated in the user manual
- The operator who performs the immobilization is the sole responsible for the choice of the collar size.
- Do not use excessive force on the connection elements between the chin support and front component, and between the neck support and posterior component.
- Regardless of the patient's condition, is necessary to carry out cleaning and disinfecting procedures after each use.
- Before use, always check that the collar has undergone the necessary cleaning procedures.
- The tapes with strap closure used to fix the collar, should always ensure a perfect fastening. Residual tissue or dirt on the tapes, may hinder their proper closure.
- Do not use the device if it has lost its original elastic properties.
- The device contains latex and may cause anaphylactic shock in subjects allergic to that substance

6.1 Physical requirements of operators

Spectar Cervical Collar is a device intended for professional use only. Each operator must be trained to transport patients safely and efficiently. Do not allow untrained persons to help operators during use of the product, as this may cause injury to themselves or to other people.

The operators that use the device must have good muscle coordination in order to ensure that immobilization procedures will not have consequences to the patient.

The abilities of all operators must be considered before determining their role in the employment of the device.

7. RESIDUAL RISK

The residual risks listed below have been identified exclusively in reference to the intended use of the device.

- The use by untrained personnel may result in injury to the patient, rescuer or others.
- Application by a single operator, may cause injury to the patient. A second operator is needed to maintain the neutral alignment of the patient's spine.
- Reuse of the device for a different patient can cause the risk of Cross-infection.
- The wrong choice of the collar size, may cause ineffective immobilization resulting in damage to the patient.
- Presence of residual tissue or dirt on the strap closures applied to the parts, can impede their proper fastening with consequent risk for the patient associated with inadequate immobilization.
- The use of a device that does not present its original characteristics of elasticity, can cause an inadequate support, resulting in damage to the patient caused by inadequate immobilization.
- Worn padding can compromise disinfection procedures increasing the risk of contamination for patients and operators.

8. TECHNICAL DATA AND COMPONENTS

Note: Spencer Italia S.r.l. reserves the right to make changes to specifications without prior notice.

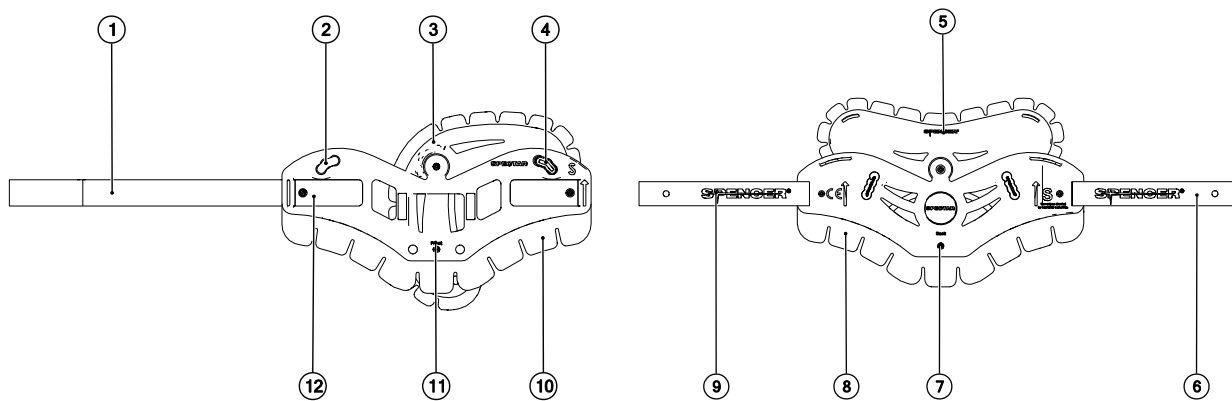

N°	Description	Material	N°	Description	Material
1	Elastic strap for front component positioning	Can contain Latex	7	Posterior component	PE
2	Buttonhole for chin support fixing	/	8	Posterior component padding	PE exp.
3	Chin support	PE/ PE exp.	9	Posterior component closing strap	Nylon
4	Clip for chin support fixing	Nylon	10	Anterior component padding	PE exp.
5	Nuchal support	PE/ PE exp.	11	Anterior component	PE
6	Posterior component closing tape	Nylon	12	Fixing zones for strap closing	Nylon

		XXS	XS	S	M	L	STOUT
	Height A	110 mm	105 mm	105 mm	115 mm	125 mm	95 mm
	Height B	55 mm	50 mm	55 mm	60 mm	65 mm	55 mm
	Height C	135 mm	115 mm	135 mm	175 mm	165 mm	125 mm
	Front component in flat position	245 mm	240 mm	295 mm	295 mm	335 mm	355 mm
	Posterior component width in flat position	235 mm	240 mm	295 mm	295 mm	335 mm	355 mm
	Weight	120 g	115 g	190 g	180 g	205 g	185 g

Note: The measures indicated above, refer to the rigid part of the components. The padding is only partially considered. For this reason, and due to the flexibility of materials, the tolerance for the dimensions **A**, **B** and **C** is ± 10 mm.

The size of the collar to be used can be chosen according to the dimensions listed above with a focus on the size **B** as generally indicated by EMS procedures.

The following table can be used as a guide line for the choice of the size of the collar:

Application	Size
Pediatric (generic)	XXS
Very short thin neck	XS
Adult men / Short necked women	S
Female / Matur women / Thin mature men	M
Long, tall neck / "Swan neck" / Young women / Adolescent	L
Very large neck circumference / Obese / Extra large shoulders	STOUT

9. START-UP

Upon receipt of the product, verify that:

- all the components are present included as indicated
- The device has not been damaged during transport

Before every use, verify:

- General functionality of the device
- Cleanliness of the device
- Absence of cuts, holes, tears and deformations on the whole structure
- All the components needed for the proper operation of the device are present.
- The strap tapes and clips properly perform their function

If the above conditions are met, the device may be considered ready for use; otherwise you must immediately remove the device from service and contact the manufacturer.

Do not alter or modify in any way the appliance; any such interference could cause malfunctions and injury to the patient and/or rescuer. Moreover the manufacturer will no longer recognize the product warranty and will accept no responsibility.

10. FUNCTIONAL CHARACTERISTICS

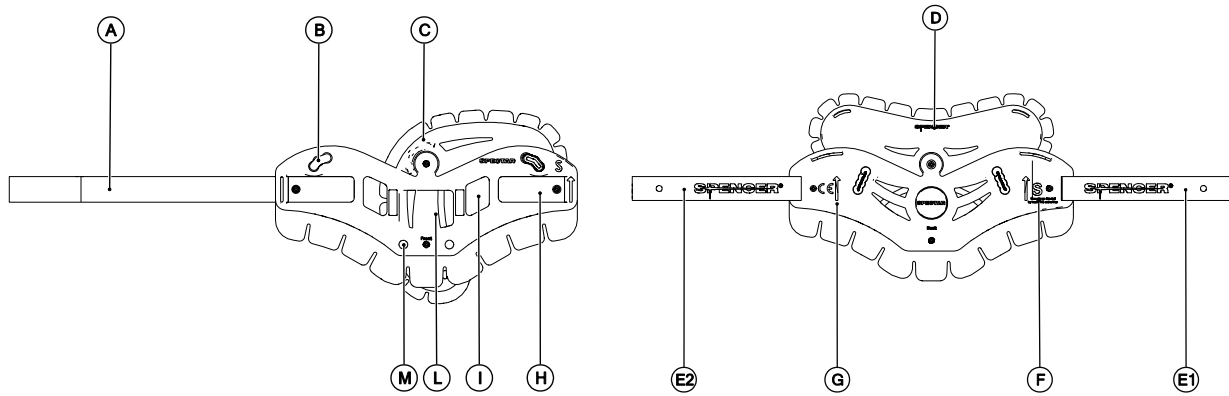

Element	Description	Function
A	Elastic strap for front component placing	The elastic strap fixed on the anterior component, equipped with a strap element that allows the anterior component placing. Once the collar is completely positioned on the patient, the terminal part of the belt A , will be placed between the element H and the element E₂ .
B	Buttonhole for chin support fixing	Needed for the placing of the clip placed on the chin support
C	Chin support	The element of the collar intended to sustain the chin. It has two red clips, that must be inserted in the anterior component. If both clips are inserted, the chin support will be in flexed position.
D	Nuchal support	Intended to sustain the occipital part. Like other parts of the collar, is covered with soft material in order to increase the comfort of the patient.
E	Posterior component closure strap	Element present on both sides of the posterior component, that allow coupling with the anterior component. Both the tapes, will cling to the elements H on the anterior component by means of the straps. Each collar size is characterized by a different tape color.
F	Size indication	Indication of the collar size. If you have more than one size of collar, always verify that the anterior and posterior component present the same size indication.
G	Arrow symbol	Indication for the operator representing the correct direction of application. The arrow indicates the direction of the head of the patient.
H	Anterior component strap	They are integrated into the body of the component on both sides. They allow the coupling of the components mating elements E . They have the same color of elements E . Verify that element H and E , have the same color
I	Opening for pulse control	Two symmetrical openings placed on the anterior component to allow control of carotid pulse with the collar applied to the patient.
L	Tracheotomy opening	Opening at the center of the anterior component that allows tracheotomy with the collar in position on the patient
M	Holes for the application of sternal support (optional)	Holes for the application of the sternal support, optional indicated in paragraph 14.

11. INSTRUCTIONS FOR USE

Before transferring, lifting or transporting the patient, primary medical evaluations have to be performed. For the use of the device the presence of at least two operators is necessary.

The following indications, refer to a generic scenario and do not integrate, nor replace the instructions issued to operators by competent bodies and/or instructors. The correct application of the collar is responsibility of the operators carrying out the immobilization procedures.

During all procedures of application of the collar, one of the operators must maintain the neutral alignment of the cervical spine.

- Ensure that there are no conditions that are incompatible with the application of the collar (ex. Neck penetrating objects).
- At purchasing, the chin support has a clip inserted into a buttonhole, and another clip free. The chin support is coupled to the anterior valv by means of an insert placed in the central part.
- Before applying the collar, the free clip of the chin support must be inserted in the buttonhole placed on the anterior component. The insertion direction is from the inside of the collar (soft side) to the outside (rigid side).
- Press the clip until it is completely inserted.
- Place the anterior part of the collar on the patient. The chin of the patient must rest on the chin support of the collar.
- Complete the positioning of the anterior component by passing the elastic strap around the patient's neck, stretching it as necessary to ensure that the anterior part is stable enough and place the straps (coupling between elements **A** and **H** described in paragraph 10).
- Place the posterior component behind the neck of the patient.
- Making sure that the other operator continues to maintain the proper alignment of the cervical spine, bring the closure tapes of the posterior component toward the anterior one, until they adhere completely to the anterior straps.
- Check that the two components perform enough sustain and compression. Otherwise carry out necessary adjustments by using the strap tapes or change the collar size, if necessary.

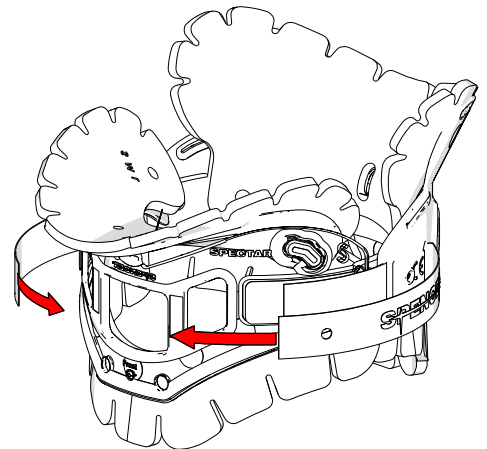
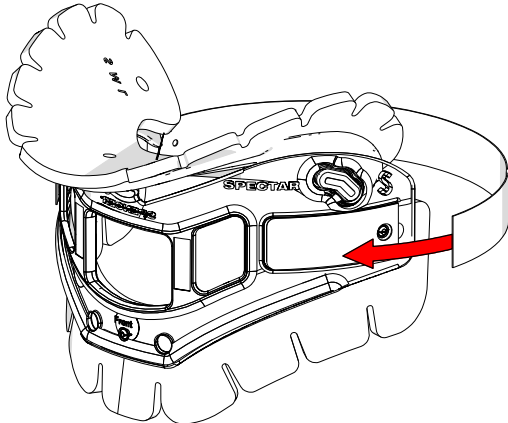
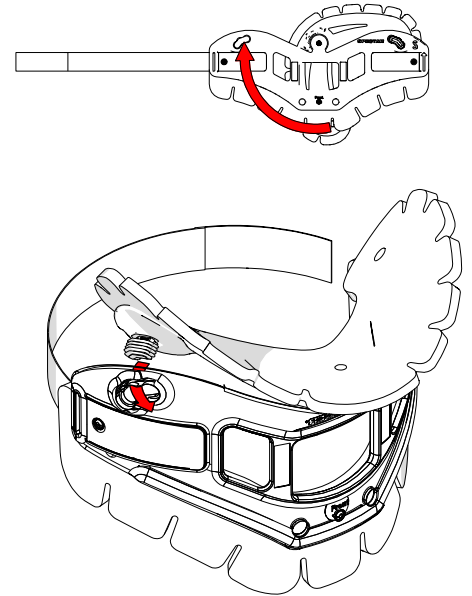

Cervical collars Spectar Foam, can be equipped with a sternal support (accessory). This component increases patient comfort and support provided by the collar. If this component is present, the operator must mount it on the anterior component when is in flat position, before the application of the collar.

- Place the sternal support between the padding and the rigid part of the anterior component, with the clips facing the outside of the collar.
- Insert the clips in the dedicated holes placed in the anterior component (element **M**) and press until they are completely inserted.

To return the collar to its original position, proceed as follows:

- Remove the posterior component by detaching the closure straps (elements **E**)
- Remove the elastic strap of the front component (element **A**)
- Disconnect one of the two sides of the chins support from the anterior component pressing the red clip from the outside to the inside of the collar using the thumbs. The other fingers will counteract the force of the thumbs resting on the inner side of the component and of the chin support. **DO NOT PULL the chin support to bring it to the original position, the clip may break.**
- Do the same to remove the sternal support if present.
- After use and cleaning, to avoid an elasticity loss of the chin support, is necessary to bring it back to the extended position. Only after is possible to store the device.

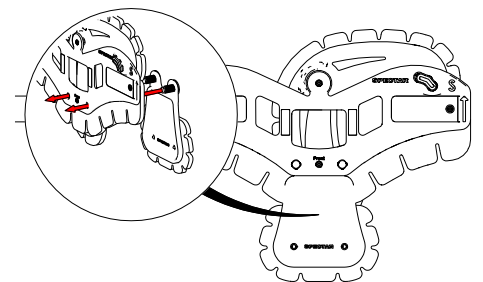

12. CLEANING AND MAINTENANCE

12.1 Cleaning

Failure to carry out the correct cleaning routine could increase the risk of cross infection, due to presence of body fluids and/or residuals. The operator must always wear adequate personal protection such as gloves and mask, etc. during all checking and cleaning procedures.

Clean and disinfect the exposed parts with water and solutions that will not cause damage to materials used for the construction of the device; **never use solvents or stain removers.**

Rinse thoroughly with warm water making sure that you have removed all traces of detergent, which could degrade or compromise the integrity and durability of the device. **The use of high pressure water should be avoided.** Allow the device to dry thoroughly before storing. Drying after washing or after use in wet environments must be natural and not forced; do not use flames or other sources of direct heat. Make sure that products used to disinfect the device not pose a risk in the event that residues of these substances come into contact with the patient.

12.2 Precautionary maintenance

Establish a maintenance program and periodic testing routine, identifying an employee responsible for this. The person to whom the ordinary maintenance of the device is entrusted must ensure the basic requirements foreseen by the manufacturer in following paragraphs are inspected.

All maintenance and periodic servicing activities must be registered and kept together with the servicing reports. These documents have to be kept for a period of 10 years after the disposal of the device itself. This register will be made available to the competent authorities and/or manufacturer if requested.

Routine maintenance of the device must be carried out by operators in possession of specific qualifications, trained and experienced in the use and maintenance of the device.

The operator must always wear adequate personal protection such as gloves and mask, etc. during all checking and cleaning procedures.

Checks to be carried out before and after each use, are as follows:

- General functionality of the device
- Cleanliness of the device (remember that the failure of cleaning may cause the risk of cross infections)
- Absence of cuts, holes, tears on the structure
- Integrity of the closure straps, both of the anterior and posterior part of the collar
- Degree of return of the chin support to its original position

The inspection frequency is determined by factors such as legal requirements, the type of use, frequency of use, environmental conditions during use and storage.

Please note that you must do the cleaning as described in this manual and verify functionality before and after each use. Spencer Italia S.r.l. declines any responsibility for the improper functioning or damages caused to the patient or user by the use of devices not subject to routine maintenance and will void the warranty and the compliance to the Medical Device Directive 93/42/CEE.

Use only accessories/original spare parts approved by Spencer Italia S.r.l., otherwise we will accept no responsibility for the incorrect functioning and/or damage caused by the use of any device which has not been repaired, or certified on expiry date by the manufacturer or by one of the manufacturer's authorised service centres. Warranty will be considered void in compliance with the Medical Device Directive 93/42/EEC.

12.3 Periodic maintenance

Periodic maintenance performed by the manufacturer is not required, but is prescribed to carry out the cleaning procedures and checks described in the "Cleaning" and "Precautionary maintenance" sections.

12.4 Special servicing

Extraordinary maintenance is not provided for this device. In case of malfunctioning or damage affecting the proper operation of the device, it must be replaced by a similar one.

12.5 Life span

The device, if used as indicated in the instruction manual, has an average life span of 2 years starting from the sale.

13. TROUBLESHOOTING

PROBLEM	CAUSE	SOLUTION
During application of the collar, the front component does not provide enough stability.	Le elastic strap of the anterior component, was not passed behind the neck of the patient	Pass the elastic strap of the anterior component behind the neck of the patient like described in the manual
	The elastic strap is worn	Put immediately the device out of service and replace it with a similar one
	The size of the collar is not correct	Verify that the size of the collar is suitable for the patient
	The chin support has not been properly fixed	Verify that the chin support is bent and the clips are properly inserted like described in the manual
Detach of the strap closures	Strap tapes are damaged	Put immediately the device out of service and replace it with a similar one
	Pieces of tissue are present in the male part of the strap closures	Clean the strap elements to ensure a perfect adherence
The fixing clips are broken	Improper use	<ul style="list-style-type: none"> - Put immediately the device out of service and replace it with a similar one - If you have spare clips, replace them by inserting the male component outside of the collar and the female one inside, making sure to insert between them the padding of the collar..
Worn padding	Unsuitable disinfectant solution has been used	Put immediately the device out of service, verify the compatibility of the solution and provide for its replacement , if necessary.
	Unsuitable storage conditions have caused premature wear	Put immediately the device out of service and verify the storage conditions
The collar doesn't provide adequate immobilization	The size of the collar is not correct	Verify that the size of the collar is suitable for the patient
	Were coupled components of different sizes	Verify that both components have the same size and the same color of the strap closures
The patient complains of discomfort cause by the collar	The collar was not correctly applied or the clinical status of the patient is not suitable for the application of the collar	<ul style="list-style-type: none"> - Verify that the collar is properly applied according to the indications reported on it - Ensure that the presence of foreign bodies in the neck is excluded before the application of the collar - A physician must determine whether the discomfort is cause to a not compatible clinical status

14. ACCESSORIES

JM30028A SPECTAR FOAM - BEARING CHEST FOR CERCIVAL COLLAR
JM00500 SPENCER COLLAR BAG - BAG W/3 BLACK NYLON COMPART.

15. SPARE PARTS

There are no spare parts of this device

16. DEMOLITION

When the device is no longer suitable for use, if they haven't been contaminated by any particular agents, they can be disposed of as normal solid waste, otherwise follow the current regulations for demolition.